

4

3

2

1

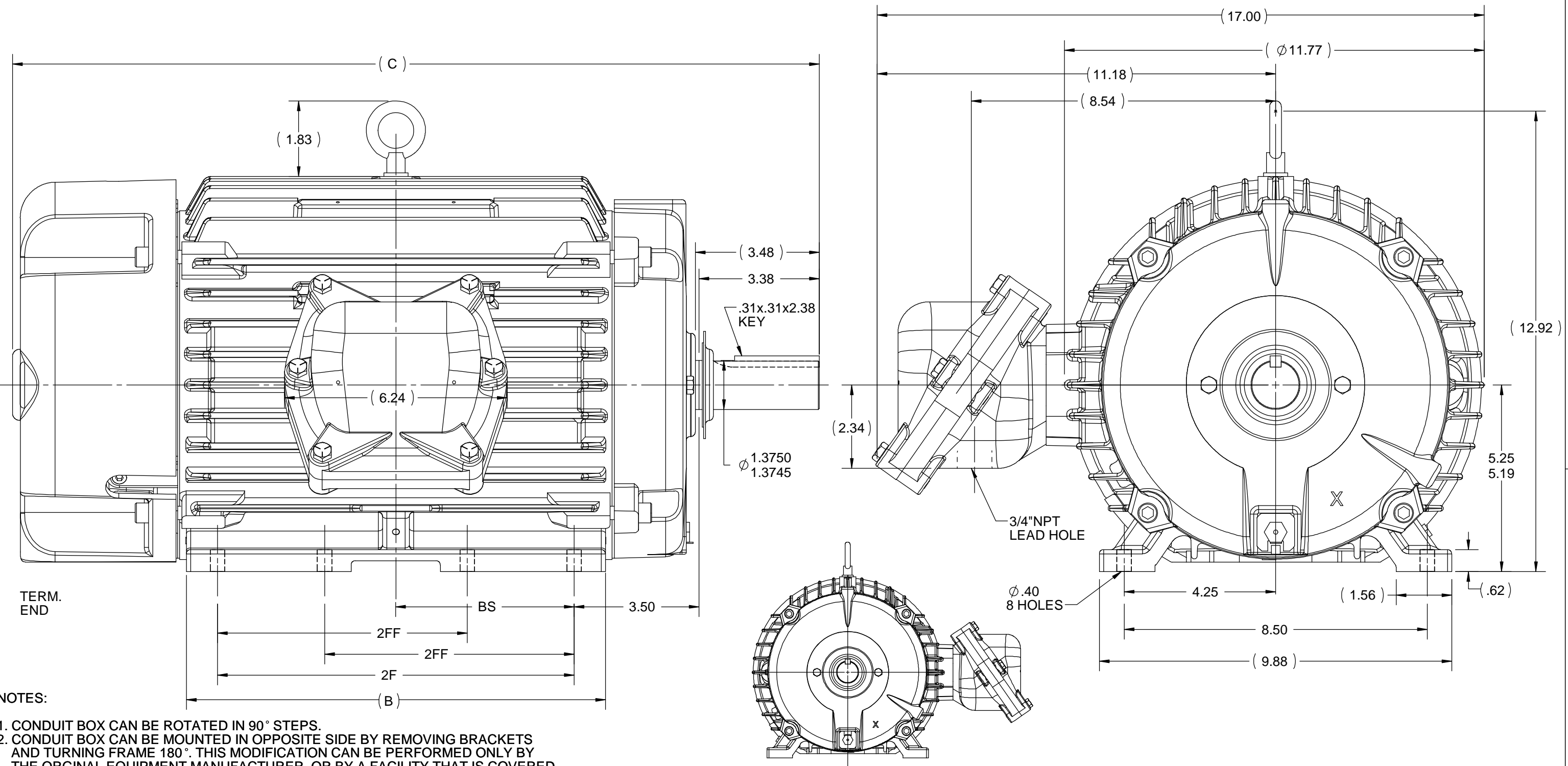

TERM.
END

- NOTES:
1. CONDUIT BOX CAN BE ROTATED IN 90° STEPS.
 2. CONDUIT BOX CAN BE MOUNTED IN OPPOSITE SIDE BY REMOVING BRACKETS AND TURNING FRAME 180°. THIS MODIFICATION CAN BE PERFORMED ONLY BY THE ORIGINAL EQUIPMENT MANUFACTURER, OR BY A FACILITY THAT IS COVERED UNDER UNDERWRITERS LABORATORIES INC. CATEGORY PTKQ, TITLED "MOTOR AND GENERATORS, REBUILT FOR USE IN HAZARDOUS LOCATION".
 3. NAMEPLATE TO BE READ FROM CONDUIT BOX SIDE OF MOTOR.

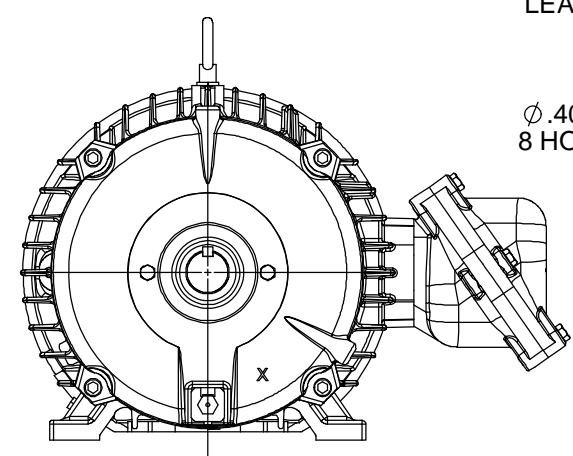

F2 MOUNTING

1212	215	22.63	11.76	10	7	5
912	213/215	19.63	8.63	7	5.5	3.5
DASH	FRAME	C	B	2F	2FF	BS

DRAWING REVISION G	REVISION BY MVG	DATE 02/08/2019	TOLERANCES UNLESS OTHERWISE SPECIFIED: DEC. INCH [mm] ANGLE .X ±0.1 [±2.5] .XX ±0.03 [±0.76] .XXX ±0.005 [±0.127] .XXXX ±0.0005 [±0.0127] REMOVE BURRS & BREAK SHARP EDGES: .003/.015 [.076/.381] X 45° CORNER FILLETS: R.02 [.51] MACHINED SURFACES: 200 INCH/mm 5.1	DRAWN BY AK 10/28/2009	Regal Beloit America, Inc.	
ECO ECO-0139404	APPROVED BY SR	DATE 02/08/2019	DATE	DESCRIPTION OUTLINE 210 FR. - EPFC		
ECO DESCRIPTION OUTLINE UPDATED AS PER ECR-0149056 COPYRIGHT REGAL BELOIT AMERICA, INC. ALL RIGHTS RESERVED. PROPRIETARY AND CONFIDENTIAL INFORMATION - THIS DOCUMENT IS THE PROPERTY OF REGAL BELOIT AMERICA, INC. ("OWNER") AND CONTAINS OWNER'S PROPRIETARY INFORMATION. ANY PERSON, CORPORATION OR OTHER FIRM RECEIVING IT IS DEEMED, BY RECEIVING IT, TO AGREE THAT IT, AND/OR ANY PART OF IT, SHALL NOT BE DISCLOSED TO ANY PERSON, CORPORATION OR OTHER ENTITY, DUPLICATED, AND/OR USED, EXCEPT AS EXPRESSLY APPROVED IN WRITING IN ADVANCE BY OWNER. THIS DOCUMENT SHALL BE RETURNED TO OWNER UPON REQUEST. IT MAY BE SUBJECT TO CERTAIN RESTRICTIONS UNDER APPLICABLE EXPORT CONTROL LAWS AND REGULATIONS.			REFERENCE SS84370	MATERIAL	PROCESS/FINISH	
			THIRD ANGLE PROJECTION	SIZE B	DRAWING NUMBER 037660	SHEET 1 OF 1

4

3

2

1